

Actuator LA33

Data sheet

LA33

The actuator LA33 is a true mid-size actuator that combines compact design and high power in one solution, fit for use in the most extreme environments. A thorough and demanding testing programme forms the basis for the maintenance-free and long lasting performance of this solid and high-quality actuator.



IC INTEGRATED CONTROLLER

This **TECHLINE**® actuator comes with IC - Integrated controller.

For more information on our IC options, please see: <https://www.linak.com/segments/techline/tech-trends/integrated-control/>

Features:

- 12 or 24 V DC Permanent magnetic motor
- Thrust from 1,500 N - 5,000 N depending on gear ratio and spindle pitch
- Max. speed up to 35 mm/sec. depending on load and spindle pitch
- Stroke length from 100 to 600 mm
- Built-in endstop switches
- Non rotating piston rod eye
- Protection class: IP66 (dynamic) and IP69K (static)

Options in general:

- Exchangeable cables in different lengths
- Hall effect sensor
- Extra socket
- IC options including:
 - IC - Integrated Controller
 - Integrated Parallel Controller
 - LIN bus communication
 - CAN bus communication
 - Analogue or digital feedback for precise positioning
 - Proportional control
 - Endstop signals
 - PC configuration tool

Usage:

- Duty cycle at 600 mm stroke is max. 20%
- Ambient operating temperature -40°C to +85°C, full performance from +5°C to +40°C

Contents

Chapter 1

Specifications	4
Technical specifications.....	5
Load versus Stroke Length	6
Stroke and built-in tolerances	6
LA33 Dimensions	7
Built-in dimensions.....	8
LA33 Piston Rod Eyes.....	9
LA33 Back fixtures	10
Back fixture orientation	11
Manual hand crank	12
Cable dimensions.....	12-13
Y-cable dimensions	12
Power cable dimensions.....	13
Signal cable dimensions	13
Speed and current curves.....	14-15

Chapter 2

I/O specifications:

Actuator without feedback.....	16
<u>Actuator with:</u>	
Endstop signal output	16
Endstop signals and relative positioning -Single Hall	17
Endstop signals and absolute positioning - Analogue feedback.....	18
Endstop signals and absolute positioning - PWM.....	19
IC Basic.....	20
IC Advanced - with BusLink	21-22
Proportional control	23-24
Parallel	25
CAN bus.....	26
IC options overview	27
Feedback configurations available for IC Advanced, Proportional and Parallel	28
Actuator configurations available for IC Advanced, Proportional and Parallel	29
System combination possibilities for LA33 IC Advanced.....	30

Chapter 3

Environmental tests - Climatic	31-32
Environmental tests - Mechanical	32
Environmental tests - Electrical	33

Chapter 1

Specifications

Motor:	Permanent magnet motor 12 or 24V DC
Cable:	Motor: 2 x 14 AWG PVC cable Control: 6 x 20 AWG PVC cable
Gear ratio:	2 different gear ratios available in steel
Brake:	Integrated brake ensures a high self-locking ability. The brake is deactivated when the actuator is powered in order to obtain a high efficiency
Hand crank:	As a standard feature the actuator can be operated manually
Housing:	The housing is made of casted aluminium, coated for outdoor use and in harsh conditions
Spindle part:	Outer tube: Extruded aluminium anodised Inner tube: Stainless steel AISI304/SS2333 Acme spindle: Trapezoidal spindle with high efficiency
Temperature range:	- 40° C to +85° C - 40° F to +185° F Full performance +5° C to +40° C
Storage temperature:	- 55°C to +105°C
Weather protection:	Rated IP66 for outdoor use. Furthermore, the actuator can be washed down with a high-pressure cleaner (IP69K)
Noise level:	73dB (A) measuring method DS/EN ISO 8746 actuator not loaded

Be aware of the following two symbols throughout this product data sheet:



Recommendations

Failing to follow these instructions can result in the actuator suffering damage or being ruined.



Additional information

Usage tips or additional information that is important in connection with the use of the actuator.

Technical specifications

LA33 with 12V motor

Type	Thrust max. Push/Pull (N)	Self-lock max. Push (N)	Self-lock max. Pull (N)	Spindle Pitch (mm) / Gear	*Typical speed (mm/s)		Stroke length (mm) in steps of 50mm			*Typical Amp. (A)	
					No load	Full load	Min.		Max.	No load	Full load
33090xxxxxxxxxA...	5000	5000	5000	9 / A	9	6	50	-	300**	2.8	10
33150xxxxxxxxxA...	3500	3500	3500	15 / A	15	9	50	-	400**	2.8	10
33150xxxxxxxxxA...	2250	2250	2250	15/B	25	21	50	-	500**	2.8	10
33200xxxxxxxxxA...	1500	1500	1500	20 / B	34	24	50	-	600	2.0	10

LA33 with 24V motor

Type	Thrust max. Push/Pull (N)	Self-lock max. Push (N)	Self-lock max. Pull (N)	Spindle Pitch (mm) / Gear	*Typical speed (mm/s)		Stroke length (mm) in steps of 50mm			*Typical Amp. (A)	
					No load	Full load	Min.		Max.	No load	Full load
33090xxxxxxxxxB...	5000	5000	5000	9 / A	9	7	50	-	300**	1.8	6.5
33150xxxxxxxxxB...	3500	3500	3500	15 / A	15	13	50	-	400**	1.8	7.0
33150xxxxxxxxxB...	2250	2250	2250	15/B	25	21	50	-	500**	1.8	6.6
33200xxxxxxxxxB...	1500	1500	1500	20 / B	35	30	50	-	600	1.8	6.5

* The typical values can have a variation of $\pm 20\%$ on the current values and $\pm 10\%$ on the speed values. Measurements are made with an actuator in connection with a stable power supply and an ambient temperature at 20°C .

** There are limitations on the stroke length if you need full load, please see "LA33 Load vs. stroke length"



- **Self locking ability**

To ensure maximum self-locking ability, please be sure that the motor is shorted when stopped. Actuators with integrated controller provide this feature, as long as the actuator is powered.

- When using soft stop on a DC-motor, a short peak of higher voltage will be sent back towards the power supply. It is important when selecting the power supply that it does not turn off the output, when this backwards load dump occurs.

Load versus stroke length

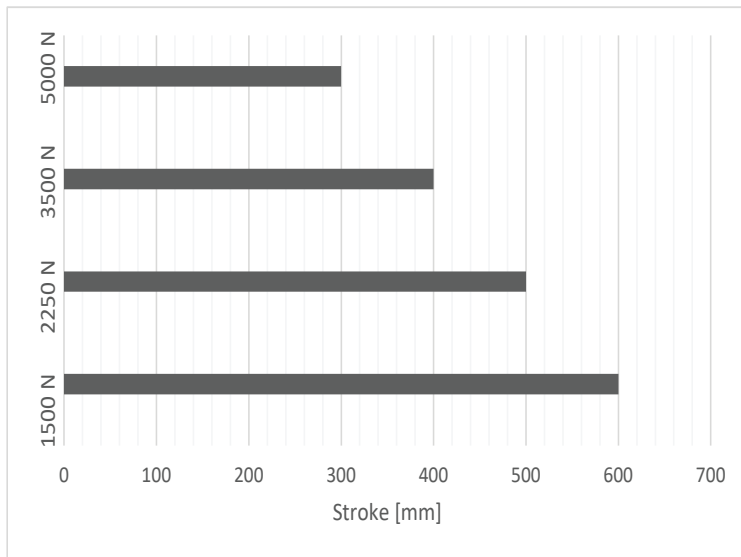

- For applications that only operate in pull the limitations are 600mm stroke and 5,000N load
- Safety factor 2

Stroke and built-in tolerances

End stop options	Descriptions	Stroke tolerance	Example for 200 mm stroke	BID tolerance	Example for 360 mm BID
All	With built-in limit switches or Integrated Controller	+/- 2 mm	198 to 202	+/- 4 mm	356 to 364

LA33 Dimensions

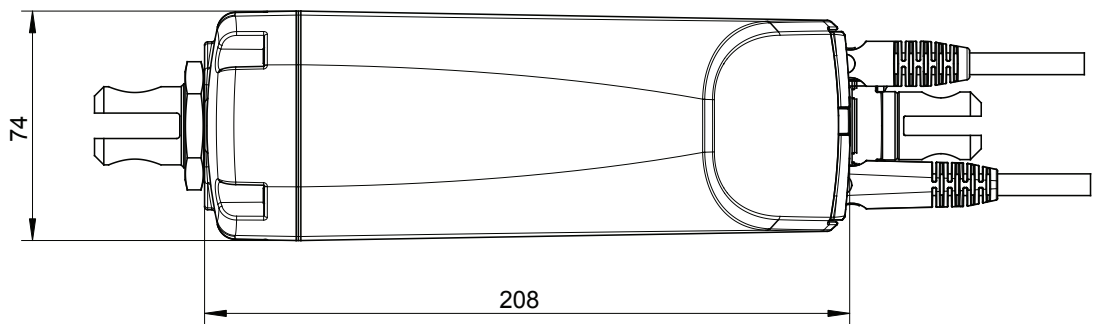
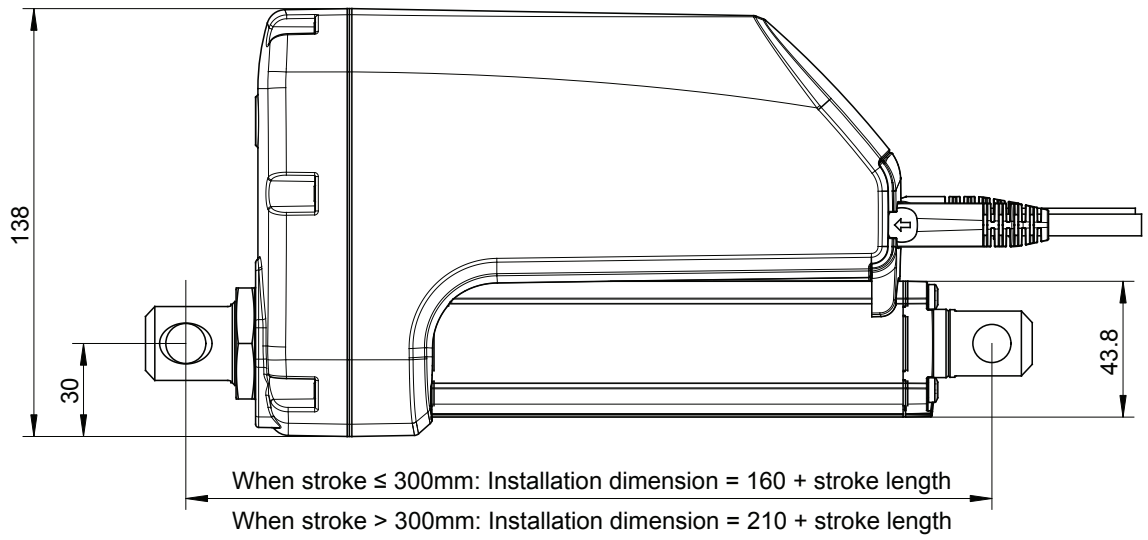

Built-in dimensions

Piston rod	"1 and A" / to the centre of the hole		"2 and B" / to the centre of the hole		"5" / from the surface		"C and D" / to the centre of the hole	
	Stroke ≤300	Stroke > 300	Stroke ≤300	Stroke > 300	Stroke ≤300	Stroke > 300	Stroke ≤300	Stroke > 300
"1" and "2" / to the centre of the hole	160	210	160	210	157*	207*	171	221
"3" and "4" / to the centre of the hole	160	210	160	210	157*	207*	171	221
"A" and "B" / to the centre of the hole	160	210	160	210	157*	207*	171	221
"C" and "D" / to the centre of the hole	160	210	160	210	157*	207*	171	221

* These built-in dimensions are measured according to the illustration below.

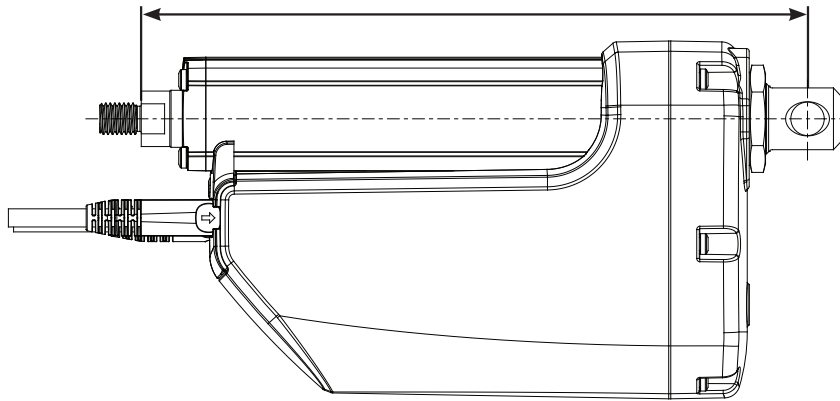

LA33 Piston Rod Eyes

Please note, that when ordering AISI (304 and up) piston rod eye and back fixture - stainless steel screws and nuts are not automatically included.

Option "1" and "A"
 Piston 0331036, Zinc coated steel
 Piston 0331140, Stainless steel AISI 304

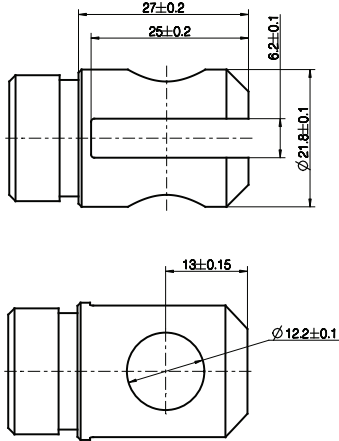

Option "2" and "B"
 Piston 0331014, Zinc coated steel
 Piston 0331139, Stainless steel AISI 304

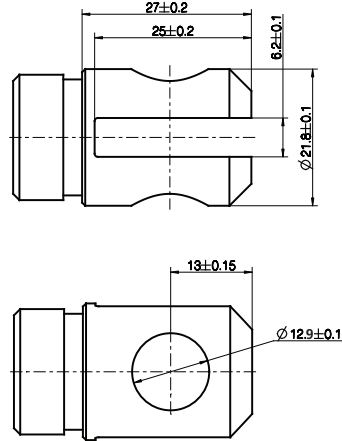

Option "C"
 Piston 0351043, Stainless steel AISI 304

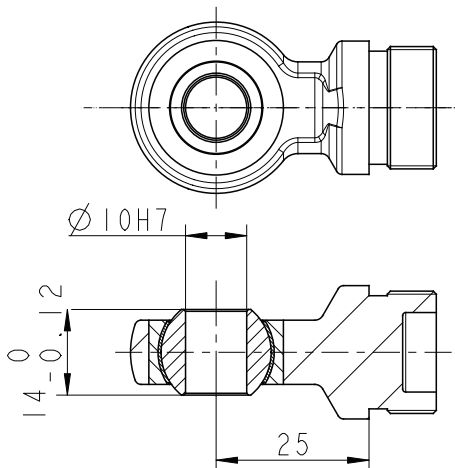

Option "D"
 Piston 0351035, Stainless steel AISI 304

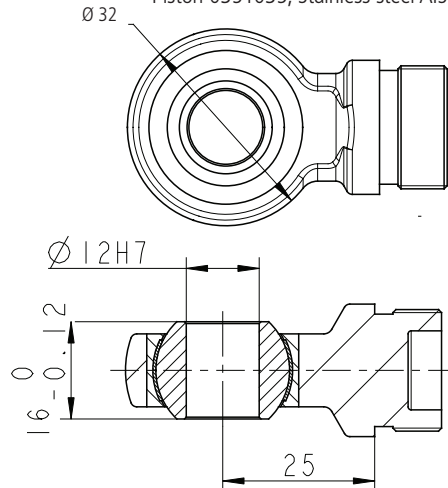

Option "5"
 Piston 0231094, Stainless steel AISI 304

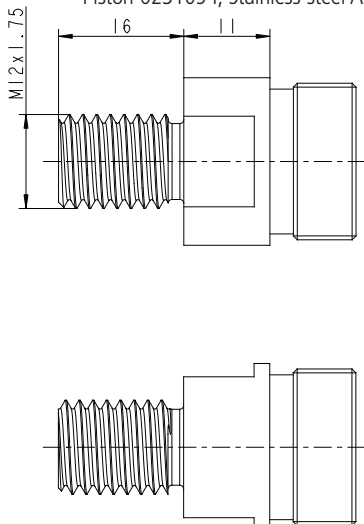

The Piston Rod Eye is only allowed to turn 0 - 90 degrees.

LA33 Back fixtures

Option "1" and "2"

LINAK P/N: 0331160, Zink coated steel

Option "A" and "B"

LINAK P/N: 0331158, Stainless steel AISI 304

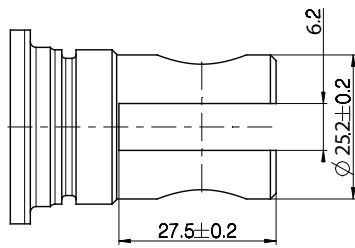
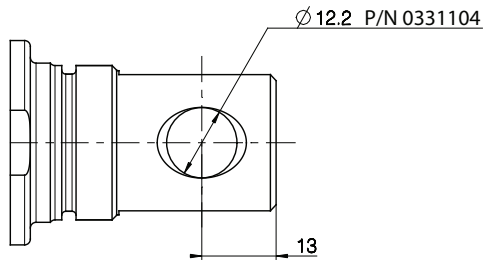

Option "3" and "4"

LINAK P/N: 0331159, Zink coated steel

Option "C" and "D"

LINAK P/N: 0331157, Stainless steel AISI 304

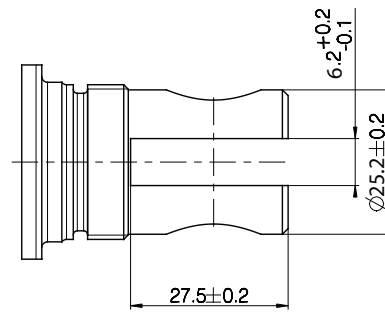
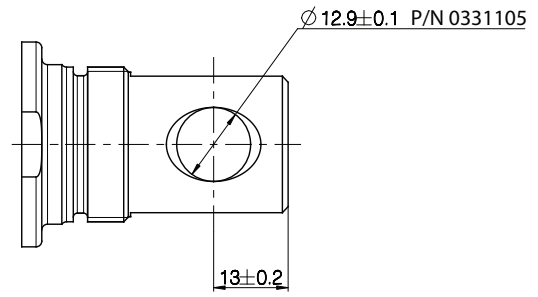

Back fixture orientation



"0" Degrees



"90" Degrees

NB. All with tolerance of $\pm 4^\circ$

Manual hand crank

The manual hand crank can be used in the case of power failure.

The cover over the Allen Key socket must be unscrewed before the Allen Key can be inserted and the Hand Crank operated.

Hand Crank Torque: 6-8 Nm

Hand Crank rpm: Max. 65



6 mm Allen key



- The power supply has to be disconnected during manual operation.
- If the actuator is operated as a Hand crank, it must only be operated by hand, otherwise there is a potential risk of overloading and hereby damaging the actuator.
- Actuators with absolute positioning must be initialised after use of the manual handcrank, because their positioning will be displaced when the power is disconnected.
- IC actuators is supplied without manual hand crank.

Cable dimensions

Y-cable dimensions:

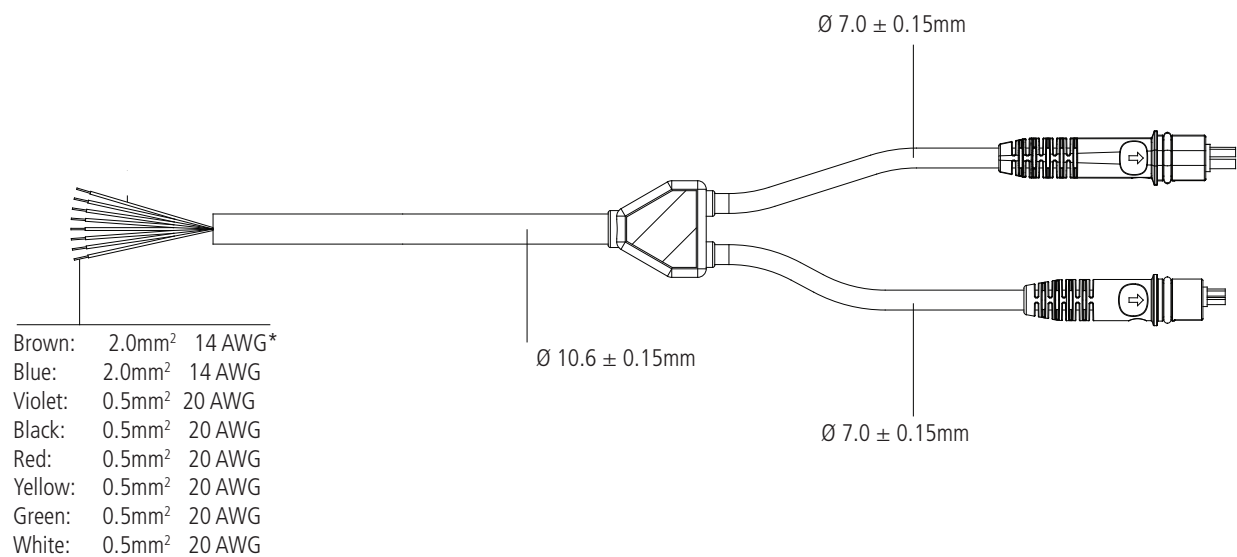

*AWG: American Wire Gauge

Cable dimensions

Power cable dimensions:

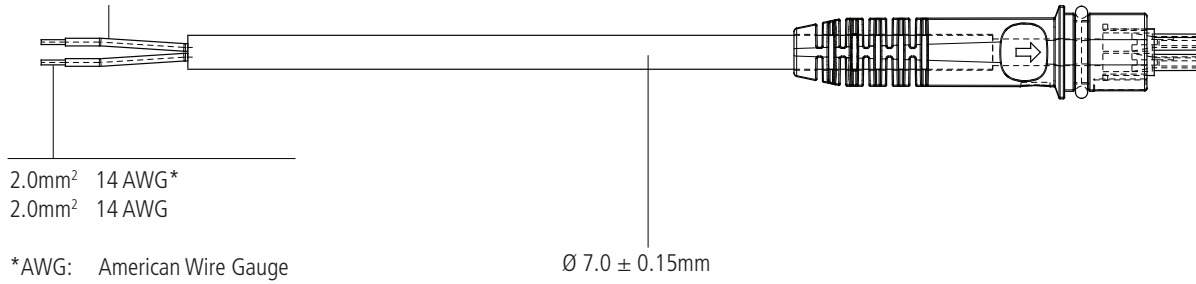

Signal cable dimensions:

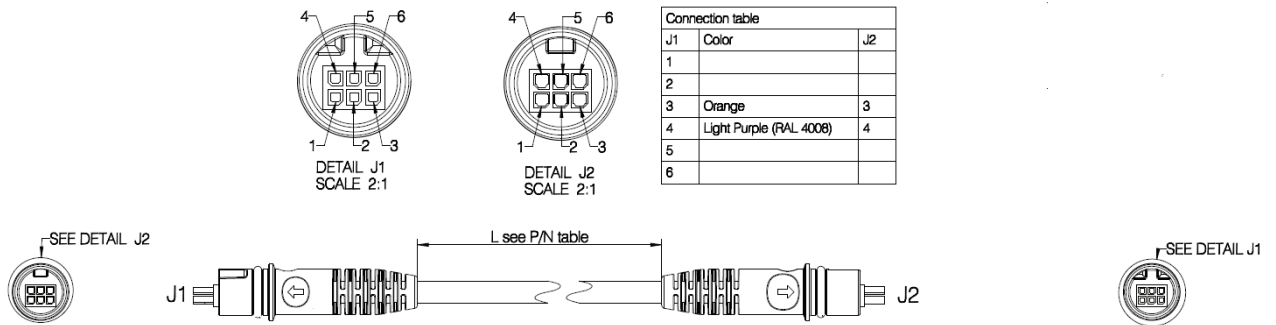

- Violet: 0.5mm² 20 AWG*
- Black: 0.5mm² 20 AWG
- Red: 0.5mm² 20 AWG
- Yellow: 0.5mm² 20 AWG
- Green: 0.5mm² 20 AWG
- White: 0.5mm² 20 AWG

Ø 7.0 ± 0.15mm

*AWG: American Wire Gauge

Speed and current curves - 12V motor

The values below are typical values and made with a stable power supply and an ambient temperature of 20°C.

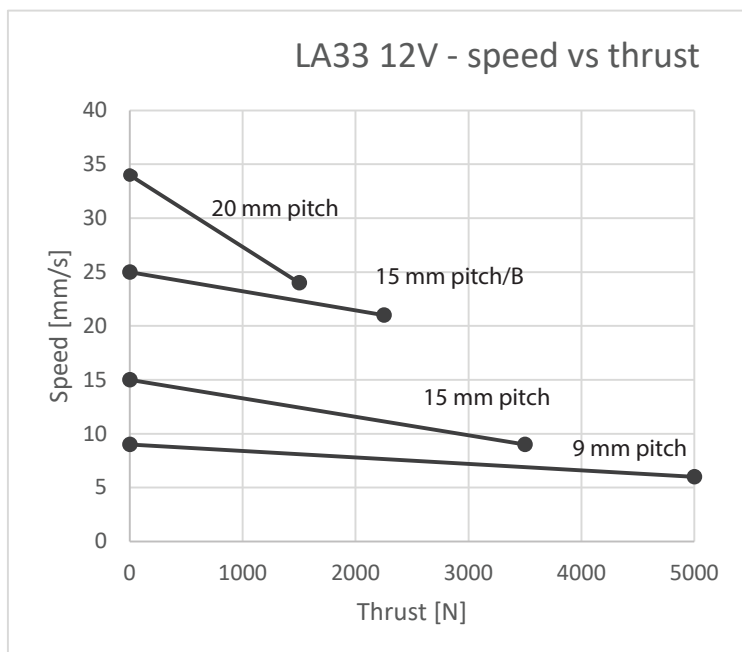
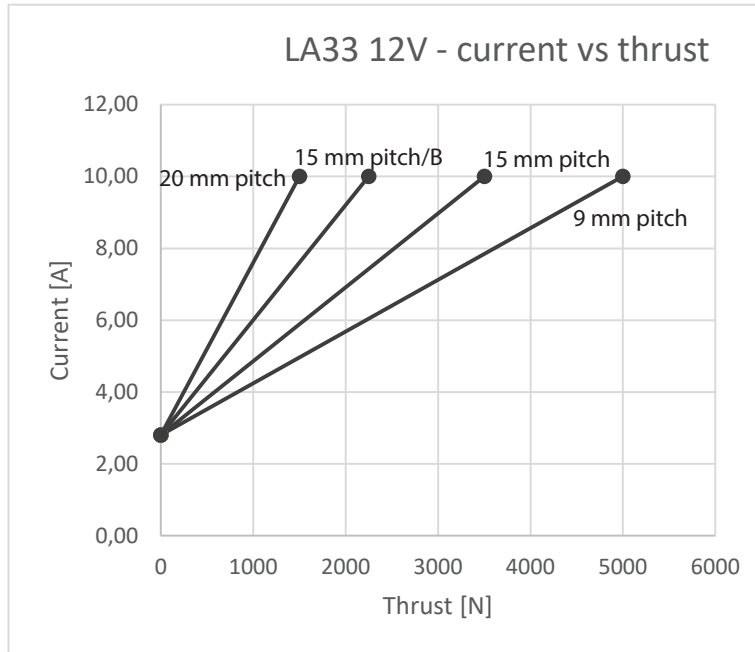

Speed and current curves - 24V motor

The values below are typical values and made with a stable power supply and an ambient temperature of 20°C.

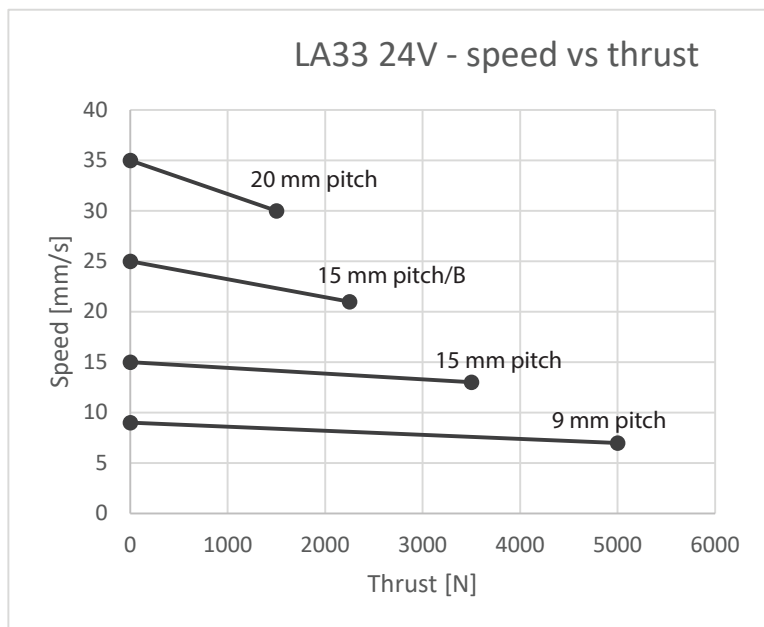
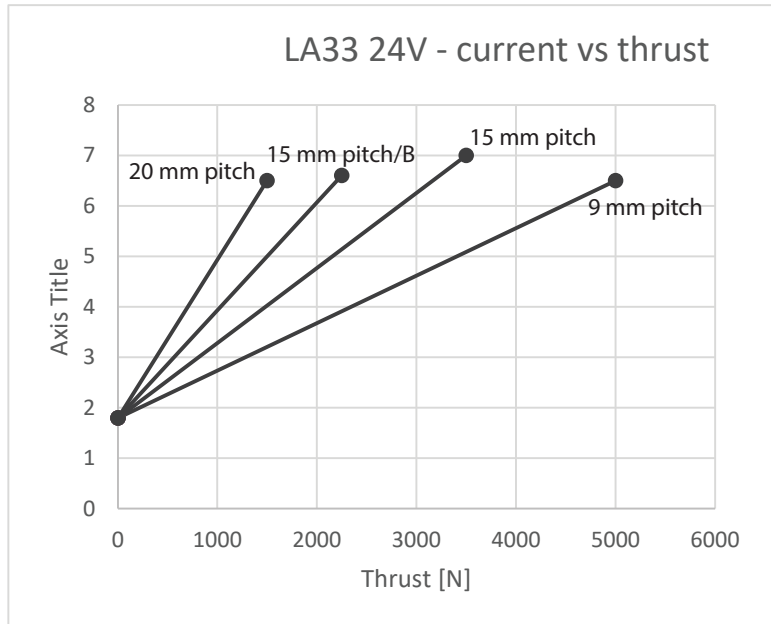

Chapter 2

I/O specifications: Actuator without feedback

Input/Output	Specification	Comments
Description	Permanent magnetic DC motor.	
Brown	12 or 24VDC (+/-) 12V ± 20% 24V ± 10%	To extend actuator: Connect Brown to positive Connect Blue to negative To retract actuator: Connect Brown to negative Connect Blue to positive
Blue	Under normal conditions: 12V, max. 12A depending on load 24V, max. 9A depending on load	
Red	Not to be connected	
Black	Not to be connected	
Green	Not to be connected	
Yellow	Not to be connected	
Violet	Not to be connected	
White	Not to be connected	

I/O specifications: Actuator with endstop signal output

Input/Output	Specification	Comments
Description	The actuator can be equipped with electronically controlled endstop signals out.	
Brown	12 or 24VDC (+/-)	To extend actuator: Connect Brown to positive Connect Blue to negative To retract actuator: Connect Brown to negative Connect Blue to positive
Blue	12V ± 20% 24V ± 10% Under normal conditions: 12V, max. 13A depending on load 24V, max. 9A depending on load	
Red	Signal power supply (+) 12-24VDC ± 10%	Current consumption: Max. 40mA, also when the actuator is not running
Black	Signal power supply GND (-)	
Green	Endstop signal out	Output voltage min. $V_{IN} - 2V$ Source current max. 100mA NOT potential free
Yellow	Endstop signal in	
Violet	Not to be connected	
White	Not to be connected	

I/O specifications: Actuator with endstop signals and relative positioning - Single Hall

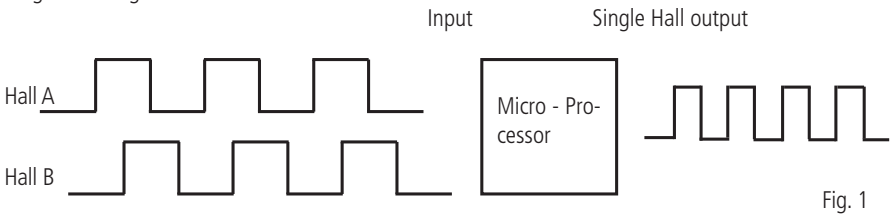
Input/Output	Specification	Comments
Description	The actuator can be equipped with Single Hall that gives a relative positioning feedback signal when the actuator moves.	
Brown	12 or 24VDC (+/-) 12V ± 20% 24V ± 10%	To extend actuator: Connect Brown to positive Connect Blue to negative
Blue	Under normal conditions: 12V, max. 13A depending on load 24V, max. 9A depending on load	To retract actuator: Connect Brown to negative Connect Blue to positive
Red	Signal power supply (+) 12-24VDC ± 10%	Current consumption: Max. 40mA, also when the actuator is not running
Black	Signal power supply GND (-)	
Green	Endstop signal out	Output voltage min. $V_{IN} - 2V$ Source current max. 100mA NOT potential free
Yellow	Endstop signal in	
Violet	Single Hall output (PNP) Movement per Single Hall pulse: 33090: Actuator = 0.3 mm per count 33150: Actuator = 0.5 mm per count 33200: Actuator = 1.1 mm per count Frequency: Frequency is up to 125 Hz on Single Hall output depending on load and spindle. Overvoltage on motor can result in shorter pulses.	Output voltage min. $V_{IN} - 2V$ Max. current output: 12mA Max. 680nF N.B. For more precise measurements, please contact your local LINAK subsidiary. Low frequency with a high load. Higher frequency with no load.
Diagram of Single Hall: 		
White	Not to be connected	

I/O specifications: Actuator with endstop signals and absolute positioning - Analogue feedback

Input/Output	Specification	Comments
Description	The actuator can be equipped with electronic circuit that gives an analogue feedback signal when the actuator moves.	
Brown	12 or 24VDC (+/-)	To extend actuator: Connect Brown to positive Connect Blue to negative To retract actuator: Connect Brown to negative Connect Blue to positive
Blue	12V \pm 20% 24V \pm 10% Under normal conditions: 12V, max. 13A depending on load 24V, max. 9A depending on load	
Red	Signal power supply (+) 12-24VDC \pm 10%	Current consumption: Max. 60mA, also when the actuator is not running
Black	Signal power supply GND (-)	
Green	Endstop signal out	Output voltage min. $V_{IN} - 2V$ Source current max. 100mA NOT potential free
Yellow	Endstop signal in	
Violet	Analogue feedback 4-20mA	Tolerances \pm 0.2mA Transaction delay 20ms Linear feedback 0.5% Output: Source Serial resistance: 12V max 300 ohm 24V max 900 ohm It is recommendable to have the actuator to activate its limit switches on a regular basis, to ensure more precise positioning
White	Not to be connected	

I/O specifications: Actuator with endstop signals and absolute positioning - PWM

Input/Output	Specification	Comments
Description	The actuator can be equipped with electronic circuit that gives an analogue feedback signal when the actuator moves.	
Brown	12 or 24VDC (+/-)	To extend actuator: Connect Brown to positive
Blue	12V \pm 20% 24V \pm 10% Under normal conditions: 12V, max. 13A depending on load 24V, max. 9A depending on load	Connect Blue to negative To retract actuator: Connect Brown to negative Connect Blue to positive
Red	Signal power supply (+) 12-24VDC \pm 10%	Current consumption: Max. 60mA, also when the actuator is not running
Black	Signal power supply GND (-)	
Green	Endstop signal out	Output voltage min. $V_{IN} - 2V$ Source current max. 100mA NOT potential free
Yellow	Endstop signal in	
Violet	Digital output feedback (PNP) 10-90% 20-80%	Output voltage min. $V_{IN} - 2V$ Tolerances +/- 2% Max. current output: 12mA Frequency: 75Hz It is recommendable to have the actuator to activate its limit switches on a regular basis, to ensure more precise positioning
White	Not to be connected	

I/O specifications: Actuator with IC Basic

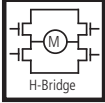
Input/Output	Specification	Comments
Description	Easy to use interface with integrated power electronics (H-bridge). The version with "IC option" cannot be operated with PWM (power supply).	
Brown	12-24VDC + (VCC) Connect Brown to positive 12V ± 20% 24V ± 10% 12V, current limit 15A 24V, current limit 10A	Note: Do not change the power supply polarity on the brown and blue wires! Power supply GND (-) is electrically connected to the housing
Blue	12-24VDC - (GND) Connect Blue to negative 12V ± 20% 24V ± 10%	If the temperature drops below 0°C, all current limits will automatically increase to: 20A for 12V 15A for 24V
Red	Extends the actuator	On/off voltages: > 67% of V_{IN} = ON < 33% of V_{IN} = OFF Input current ≈ 10mA
Black	Retracts the actuator	
Green	Endstop signal out	Output voltage min. $V_{IN} - 2V$ Source current max. 100mA
Yellow	Endstop signal in	Endstop signals are NOT potential free. Endstop signals can be configured with BusLink software according to any position needed When configuring virtual endstop, it is not necessary to choose the position feedback EOS and virtual endstop will work even when feedback is not chosen
Violet	Not to be connected	
White	Not to be connected	

I/O specifications: Actuator with IC Advanced - with BusLink

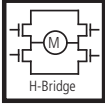
Input/Output	Specification	Comments
Description	<p>Easy to use interface with integrated power electronics (H-bridge).</p> <p>The actuator can also be equipped with electronic circuit that gives an absolute or relative feedback signal. IC Advanced provides a wide range of possibilities for customisation.</p> <p>The version with "IC option" cannot be operated with PWM (power supply).</p>	 <p>The diagram shows a square H-bridge circuit with a motor symbol (M) in the center. The bridge consists of four transistors (represented by rectangles) connected to a central motor. The text "H-Bridge" is written below the diagram.</p>
Brown	<p>12-24VDC + (VCC) Connect Brown to positive</p> <p>12V ± 20% 24V ± 10%</p> <p>12V, current limit 15A 24V, current limit 10A</p>	<p>Note: Do not change the power supply polarity on the brown and blue wires!</p> <p>Power supply GND (-) is electrically connected to the housing</p> <p>Current limit levels can be adjusted through BusLink</p>
Blue	<p>12-24VDC - (GND) Connect Blue to negative</p> <p>12V ± 20% 24V ± 10%</p>	<p>If the temperature drops below 0°C, all current limits will automatically increase to: 20A for 12V 15A for 24V</p>
Red	Extends the actuator	<p>On/off voltages:</p> <p>> 67% of V_{IN} = ON < 33% of V_{IN} = OFF</p>
Black	Retracts the actuator	<p>Input current ≈ 10mA</p>
Green	Endstop signal out	<p>Output voltage min. $V_{IN} - 2V$ Source current max. 100mA</p> <p>Endstop signals are NOT potential free. Endstop signals can be configured with BusLink software according to any position needed</p>
Yellow	<p>Endstop signal in (Option 1) Constantly high (Option 2)</p>	<p>When configuring virtual endstop, it is not necessary to choose the position feedback</p> <p>EOS and virtual endstop will work even when feedback is not chosen</p>

I/O specifications: Actuator with IC Advanced - with BusLink

Input/Output	Specification	Comments
Violet	Analogue feedback (0-10V): Configure any high/low combination between 0-10V	Ripple max. 200mV Transaction delay 20ms Linear feedback 0.5% Max. current output. 1mA
	Single Hall output (PNP) Movement per Single Hall pulse: 33090: Actuator = 0.3 mm per count 33150: Actuator = 0.5 mm per count 33200: Actuator = 1.1 mm per count Frequency: Frequency is up to 125 Hz on Single Hall output depending on load and spindle. Overvoltage on the motor can result in shorter pulses	Output voltage min. $V_{IN} - 2V$ Max. current output: 12mA Max. 680nF Open collector source current max. 12mA
	Digital output feedback PWM: Configure any high/low combination between 0-100%	Output voltage min. $V_{IN} - 2V$ Frequency: 75Hz \pm 10Hz as standard, but this can be customised. Duty cycle: Any low/high combination between 0 and 100 percent. Open collector source current max. 12mA
	Analogue feedback (4-20mA): Configure any high/low combination between 4-20mA	Tolerances \pm 0.2mA Transaction delay 20ms Linear feedback 0.5% Output: Source Serial resistance: 12V max. 300 ohm 24V max. 900 ohm
	All absolute value feedbacks (0-10V, PWM and 4-20mA)	Standby power consumption: 12V, 85mA 24V, 50mA It is recommendable to have the actuator to activate its limit switches on a regular basis, to ensure more precise positioning
White	Signal GND	



The BusLink software tool is available for IC Advanced and can be used for:

Diagnostics, manual run and configuration.

Please note that the BusLink cables must be purchased separately from the actuator!

Item number for BusLink cable kit: 0367999 (adaptor + USB2Lin)

I/O specifications: Actuator with proportional control

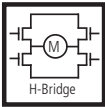
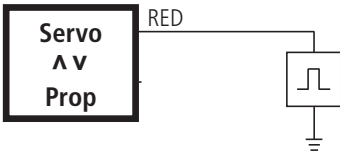
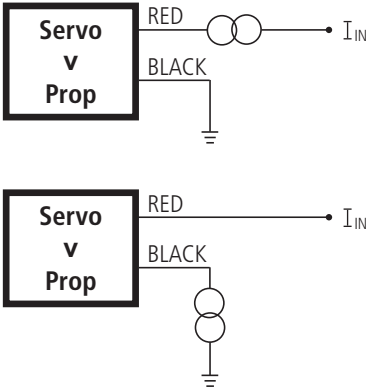
Input/Output	Specification	Comments
Description	<p>Easy to use interface with integrated power electronics (H-bridge).</p> <p>The actuator is speed controlled by means of a PWM or 4-20mA signal.</p> <p>Proportional provides a wide range of possibilities for customisation.</p>	
Brown	<p>12-24VDC + (VCC) Connect Brown to positive</p> <p>12V ± 20% 24V ± 10%</p> <p>12V, current limit 15A 24V, current limit 10A</p>	<p>Note: Do not change the power supply polarity on the brown and blue wires!</p> <p>Power supply GND (-) is electrically connected to the housing</p> <p>If the temperature drops below 0°C, all current limits will automatically increase to:</p>
Blue	<p>12-24VDC - (GND) Connect Blue to negative</p> <p>12V ± 20% 24V ± 10%</p>	<p>20A for 12V 15A for 24V</p>
Red Black	<p>PWM:</p>  <p>4-20mA:</p> 	<p>Signal levels:</p> <p>> 10V = High < 2V = Low with reference to power GND (blue)</p> <p>Equivalent input resistance ≈ 22k</p> <p>Frequency: Min. 100Hz Max. 1000Hz</p> <p>Overcurrent protected, reverse voltage protected</p> <p>Sinking current with reference to power GND (blue)</p> <p>Common mode voltage: GND to V supply</p> <p>Equivalent input resistance ≈ 135ohm</p> <p>Overcurrent protected, reverse voltage protected</p>
Green	Endstop signal out	<p>Output voltage min. $V_{IN} - 2V$ Source current max. 100mA</p> <p>Endstop signals are NOT potential free. Endstop signals can be configured with BusLink software according to any position needed.</p>
Yellow	Endstop signal in	<p>When configuring virtual end stop, it is not necessary to choose the position feedback</p> <p>EOS and Virtual end stop will work even when feedback is not chosen</p>

I/O specifications: Actuator with proportional control

Input/Output	Specification	Comments
Violet	Analogue feedback (0-10V): Configure any high/low combination between 0-10V	Ripple max. 200mV Transaction delay 20ms Linear feedback 0.5% Max. current output. 1mA
	Single Hall output (PNP) Movement per Single Hall pulse: 33090: Actuator = 0.3 mm per count 33150: Actuator = 0.5 mm per count 33200: Actuator = 1.1 mm per count Frequency: Frequency is up to 125 Hz on Single Hall output depending on load and spindle. Overvoltage on the motor can result in shorter pulses	Output voltage min. $V_{IN} - 2V$ Max. current output: 12mA Max. 680nF
	Digital output feedback PWM: Configure any high/low combination between 0-100%	Output voltage min. $V_{IN} - 2V$ Frequency: 75Hz \pm 10Hz as standard, but this can be customised. Duty cycle: Any low/high combination between 0 and 100 percent. Open collector source current max. 12mA
	Analogue feedback (4-20mA): Configure any high/low combination between 4-20mA	Tolerances \pm 0.2mA Transaction delay 20ms Linear feedback 0.5% Output: Source Serial resistance: 12V max. 300 ohm 24V max. 900 ohm
	All absolute value feedbacks (0-10V, PWM and 4-20mA)	Standby power consumption: 12V, 85mA 24V, 50mA It is recommendable to have the actuator to activate its limit switches on a regular basis, to ensure more precise positioning
White	Signal GND	

I/O specifications: Actuator with Parallel

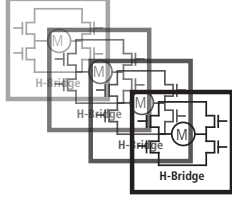
Input/Output	Specification	Comments
Description	<p>Parallel drive of up to 8 actuators. A master actuator with an integrated H-bridge controller controls up to 7 slaves.</p> <p>The version with "IC option" cannot be operated with PWM (power supply).</p>	
Brown	<p>12-24VDC + (VCC) Connect Brown to positive</p> <p>12V ± 20% 24V ± 10%</p> <p>12V, current limit 15A 24V, current limit 10A</p>	<p>Note: Do not change the power supply polarity on the brown and blue wires!</p> <p>The parallel actuators can run on one OR separate power supplies</p> <p>Power supply GND (-) is electrically connected to the housing</p>
Blue	<p>12-24VDC - (GND) Connect Blue to negative</p> <p>12V ± 20% 24V ± 10%</p>	<p>Current limit levels can be adjusted through Bus-Link (only one actuator at a time for parallel)</p> <p>If the temperature drops below 0°C, all current limits will automatically increase to 20A for 12V 15A for 24V</p>
Red	Extends the actuator	<p>On/off voltages:</p> <p>> 67% of V_{IN} = ON < 33% of V_{IN} = OFF</p> <p>Input current ≈ 10mA</p>
Black	Retracts the actuator	It does not matter where the in/out signals are applied. You can either choose to connect the signal cable to one actuator OR you can choose to connect the signal cable to each actuator on the line. Either way this will ensure parallel drive
Green	Endstop signal out	Output voltage min. $V_{IN} - 2V$ Source current max. 100mA
Yellow	Endstop signal in	Endstop signals are NOT potential free. Endstop signals can be configured with BusLink software according to any position needed
Violet	<p>Parallel communication: Violet cords must be connected together</p>	<p>Standby power consumption: 12V, 85mA 24V, 50mA</p> <p>No feedback available during parallel drive</p>
White	<p>Signal GND: White cords must be connected together</p>	



The BusLink software tool is available for Parallel and can be used for:

Diagnostics, manual run and configuration.

Please note that the BusLink cables must be purchased separately from the actuator!

Item number for BusLink cable kit: 0367999 (adaptor + USB2Lin)

I/O specifications: Actuator with CAN bus

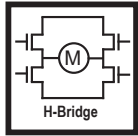
Input/Output	Specification	Comments
Description	<p>Compatible with the SAE J1939 standard. Uses CAN messages to command movement, setting parameters and to deliver feedback from the actuator. See the LINAK CAN bus user manual.</p> <p>Actuator identification is provided, using standard J1939 address claim or fixed addresses.</p> <p>See connection diagram, fig. 16, page 66</p>	
Brown	<p>12-24VDC + (VCC) Connect Brown to positive</p> <p>12V ± 20% 24V ± 10%</p> <p>12V, current limit 15A 24V, current limit 10A</p>	<p>Note: Do not swap the power supply polarity on the brown and blue wires!</p> <p>Power supply GND (-) is electrically connected to the housing</p> <p>Current limit levels can be adjusted through BusLink</p>
Blue	<p>12-24VDC - (GND) Connect Blue to negative</p>	<p>If the temperature drops below 0°C, all current limits will automatically increase to 20A for 12V and 15A for 24V.</p>
Red	Extends the actuator	<p>On/off voltages:</p> <p>> 67% of V_{IN} = ON < 33% of V_{IN} = OFF</p>
Black	Retracts the actuator	
Green	CAN_L	<p>LA33 with CAN bus does not contain the 120Ω terminal resistor. The physical layer is in accordance with J1939-15.*</p> <p>Speed:Baudrate: 250 kbps</p> <p>Max bus length: 40 meters</p> <p>Max stub length: 3 meters</p> <p>Max node count: 10 (can be extended to 30 under certain circumstances)</p> <p>Wiring: Unshielded twisted pair</p> <p>Cable impedance: 120 Ω (±10%)</p>
Yellow	CAN_H	
Violet	Service interface	<p>Only BusLink can be used as service interface. Use green adapter cable</p>
White	Service interface GND	

* J1939-15 refers to Twisted Pair and Shielded cables. The standard/default cables delivered with LA33 CAN do not comply with this.

IC options overview

	Basic	Advanced	Parallel	Proportional	LIN bus	CAN bus
Control						
12V, 24V supply	√	√	√	√	√	√
H-bridge	√	√	√	√	√	√
Manual drive in/out	√	√	√	-	√	√
EOS in/out	√	√	√	√	√	√
Soft start/stop	√	√	√	√	√	√
Feedback						
Voltage	-	√*	-	√*	-	-
Current	-	√**	-	√**	-	-
Single Hall	-	√	-	√	-	-
PWM	-	√*	-	√	-	-
Position (mm)	-	-	-	-	√	√
Custom feedback type	-	√	-	√	-	-
Monitoring						
Temperature monitoring	√	√	√	√	√	√
Current cut-off	√	√	√	√	√	√
BusLink (...)						
Service counter	-	√	√	√	√	√
Custom soft start/stop	-	√***	√***	√***	√***	√***
Custom current limit	-	√	√	√	√	√
Speed setting	-	√	√	√	√	√
Virtual end stop	-	√	√	√	√	√

* Configure any high/low combination between 0 - 10V

** Configure any high/low combination between 4 - 20mA

*** Configure any value between 0 - 30s

Feedback configurations available for IC Advanced, Proportional and Parallel

	Pre-configured	Customised range	Pros	Cons
None			N/A	N/A
PWM Feedback	10 – 90 % 75 Hz	0 – 100 % 75 – 150 Hz	Suitable for long distance transmission. Effectual immunity to electrical noise.	More complex processing required, compared to AFV and AFC.
Single Hall	N/A	N/A	Suitable for long distance transmission.	No position indication.
Analogue Feedback Voltage (AFV)	0 - 10V	Any combination, going negative or positive. E.g. 8.5 – 2.2V over a full stroke.	High resolution. Traditional type of feedback suitable for most PLCs. Easy faultfinding. Independent on stroke length, compared to a traditional mechanical potentiometer.	Not recommended for applications with long distance cables or environments exposed to electrical noise.
Analogue Feedback Current (AFC)	4 - 20mA	Any combination, going negative or positive. E.g. 5.5 – 18mA over a full stroke.	High resolution. Better immunity to long cables and differences in potentials than AFV. Provides inherent error condition detection. Independent on stroke length, compared to a traditional mechanical potentiometer.	Higher power consumption compared to AVF. Not suitable for signal isolation.
Endstop signal in/out	At physical end stops. Default for IC Advanced.	Any position.	Can be set at any position over the full stroke length.	Only one endstop can be customised.



All feedback configurations are available for IC Advanced and Proportional
* Parallel feedback configurations available: EOS

Actuator configurations available for IC Advanced, Proportional and Parallel

	Pre-configured	Customised range	Description
Current limit inwards*	10A for both current limit directions. (When the current outputs are at zero, it means that they are at maximum value 10A). Be aware: When the actuator comes with current cut-off limits that are factory pre-configured for certain values, the pre-configured values will be the new maximum level of current cut-off.	Recommended range: 3A to 10A If the temperature drops below 0°C, all current limits will automatically increase to 15A for 24V, and 20A for 12V, independent of the pre-configured value.	The actuator's unloaded current consumption is very close to 4A, and if the current cut-off is customised below 4A there is a risk that the actuator will not start. The inwards and outwards current limits can be configured separately and do not have to have the same value.
Current limit outwards*	This means that if the current cut-off limits are pre-configured to 7A, it will not be possible to change the current limits through BusLink to go higher than 7A. If the temperature drops below 0°C, all current limits will automatically increase to 15A for 24V, and 20A for 12V, independent of the pre-configured value.		
Max. speed inwards/ outwards	100% equal to full performance. Please note: for parallel actuators the full performance equals 80% of the max. speed.	Lowest recommended speed at full load: 60% It is possible to reduce the speed below 60%, but this is dependable on load, power supply and the environment.	The speed is based on a PWM principle, meaning that 100% equals the voltage output of the power supply in use, and not the actual speed.
Virtual endstop inwards	0mm for both virtual endstop directions. (When the virtual endstops are at zero, it means that they are not in use).	It is only possible to run the actuator with one virtual endstop, either inwards or outwards.	The virtual endstop positions are based on hall sensor technology. The positioning needs to be initialised from time to time, by reaching one of the physical endstops of the actuator, which must be available for initialisation.
Virtual endstop outwards			
Soft stop inwards	0.3 sec. for both soft stop directions.	0.3 sec. to 30 sec. 0 sec. can be chosen for hard stop.	It is not possible to configure values between 0.01 sec. to 0.29 sec. This is due to the back-EMF from the motor (increasing the voltage). Be aware that the soft stop value equals the deceleration time after stop command.
Soft stop outwards			
Soft start inwards	0.3 sec. for both soft start directions.	0 sec. to 30 sec.	Be aware that the soft start value equals the acceleration time after start command. To avoid stress on the actuator, it is not recommended to use 0 sec. for soft start, due to higher inrush current.
Soft start outwards			

System combination possibilities for LA33 IC Advanced

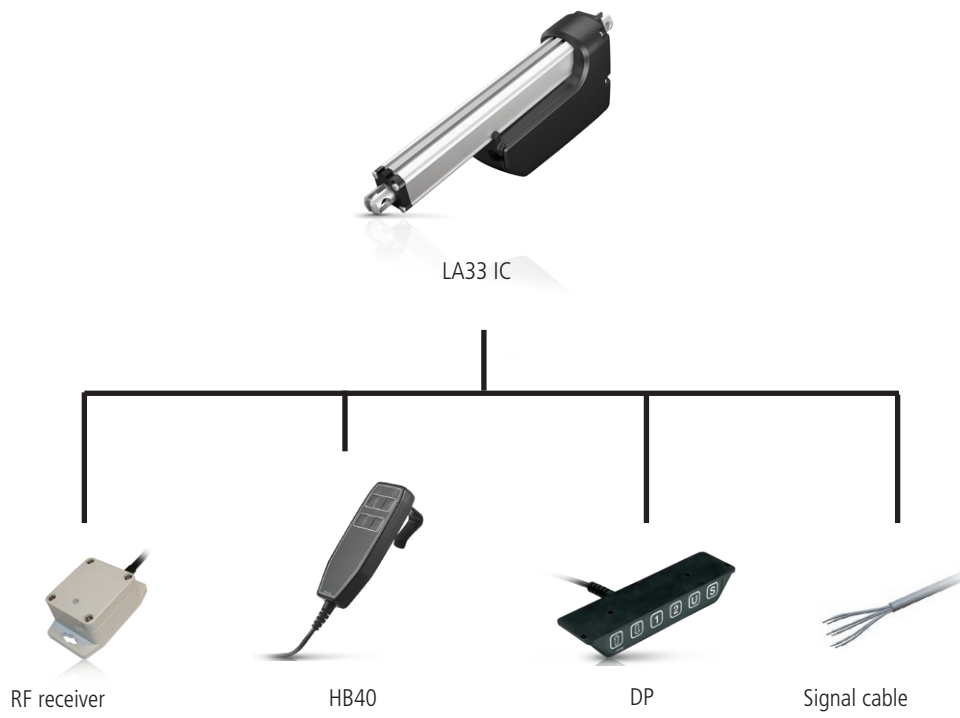

Chapter 3

Environmental tests - Climatic

Test	Specification	Comment
Cold test	EN60068-2-1 (Ab)	Storage at low temperature: Temperature: - 40°C Duration: 72 h Actuator is not connected/operated Tested at room temperature
		Storage at low temperature: Temperature: -55°C Duration: 24 h Actuator is not connected Tested at room temperature
	EN60068-2-1 (Ad)	Operating at low temperature: Temperature: -40°C Duration: 4 h Tested at room temperature within 5 minutes overload
Dry heat	EN60068-2-2 (Bb)	Storage at high temperature: Temperature: +85°C Duration: 72 h Actuator is not connected/operated Tested at room temperature
	EN60068-2-2 (Bb)	Storage at low temperature: Temperature: +105°C Duration: 24 h Actuator operated at high temperature
Damp heat	EN60068-2-30 (Db)	Damp heat, Cyclic: Relative humidity: 93 - 98 % High temperature: +55°C in 12 hours Low temperature: +25°C in 12 hours Duration: 21 cycles * 24 hours Actuator is operated during test
Salt mist.	EN ISO 9227	Dynamic salt spray test: Salt solution: 5% sodium chloride (NaCl) Temperature: 35 ± 2°C Duration: 500 h Actuator is operated
Thermal shock		Dunk test: Actuator is heated to +85°C for 4 h and submerged into a 0°C cold salt-water-detergent solution for 2 h Followed by 18 h dry time Duration: 5 cycles

Environmental tests - Climatic

Degrees of protection	EN60529 - IP66	IP6X - Dust: Dust-tight, No ingress of dust Actuator is not activated
	EN60529 - IP66	IPX6 - Water: Ingress of water in quantities causing harmful effects is not allowed Duration: 100 litres pr. minute in 3 minutes Actuator is not activated
	DIN40050 - IP69K	IPX9K: High pressure cleaner Temperature: +80°C Water pressure: 80 - 100 bar Water flow: 14 - 16 l/min Duration: 30 sec. each at 4 different angles 0°, 30°, 60° and 90° Actuator is not activated Ingress of water in quantities causing harmful effects is not allowed

Environmental tests - Mechanical

Test	Specification	Comment
Mechanical Shock (Handling) - Drop test		3 drops on 6 faces onto a concrete floor. Drop height: 500 mm on all faces
Vibration Random	The specification is based on ISO 16750-3:2012(E) Test VII and should therefore be performed according to IEC 60068-2-64, random vibration. The PSD level is increased in the frequency range from 10 to 400[Hz]	Random vibration: From 10Hz to 2000 Hz Duration: 32 h/axis Acceleration: 6.9 [g _{rms}]

Environmental tests - Electrical

Standard	Specification	FOCUS ON
EN/IEC 60204-1:2006 + A1:2009 + AC:2010	Safety of machinery - Electrical equipment of machines - Part 1: General requirements	<ul style="list-style-type: none"> INDUSTRIAL AUTOMATION
EN/IEC 61000-6-1: 2007	Electromagnetic compatibility (EMC) - Part 6-1: Generic standards - Immunity for residential, commercial and light industrial environments	<ul style="list-style-type: none"> INDUSTRIAL AUTOMATION
EN/IEC 61000-6-2: 2005 + AC:2005	Electromagnetic compatibility (EMC) - Part 6-2: Generic standards - Immunity for industrial environments	<ul style="list-style-type: none"> INDUSTRIAL AUTOMATION
EN/IEC 61000-6-3: 2007 + A1:2011 + AC:2012	Electromagnetic compatibility (EMC) - Part 6-3: Generic standards - Emission standard for residential, commercial and light-industrial environments	<ul style="list-style-type: none"> INDUSTRIAL AUTOMATION
EN/IEC 61000-6-4: 2007 + A1:2011	Electromagnetic compatibility (EMC) - Part 6-4: Generic standards: Emission standard for industrial environments	<ul style="list-style-type: none"> INDUSTRIAL AUTOMATION
ISO 16750-2:2012	Environmental conditions and testing for electrical and electronic equipment - Part 2: Electrical loads	<ul style="list-style-type: none"> ROAD VEHICLES
ISO 7637-2:2011	Electrical disturbances from conduction and coupling - Part 2: Electrical transient conduction along supply lines only	<ul style="list-style-type: none"> ROAD VEHICLES
ISO 7637-3:2007	Electrical disturbances from conduction and coupling - Part 3: Electrical transient transmission by capacitive and inductive coupling via lines other than supply lines	<ul style="list-style-type: none"> ROAD VEHICLES
CISPR 25 IEC:2008	Radio disturbance characteristics – Limits and methods of measurement for the protection of on-board receivers	<ul style="list-style-type: none"> VEHICLE, BOATS AND INTERNAL COMBUSTION ENGINES
ISO 11452-1, 2, 4		



All electrical tests are conducted and radiated emission (EMC) tests.

Terms of use

The user is responsible for determining the suitability of LINAK products for specific application. LINAK takes great care in providing accurate and up-to-date information on its products.

However, due to continuous development in order to improve its products, LINAK products are subject to frequent modifications and changes without prior notice. Therefore, LINAK cannot guarantee the correct and actual status of said information on its products.

While LINAK uses its best efforts to fulfill orders, LINAK cannot, for the same reasons as mentioned above, guarantee the availability of any particular product. Therefore, LINAK reserves the right to discontinue the sale of any product displayed on its website or listed in its catalogues or other written material drawn up by LINAK.

All sales are subject to the Standard Terms of Sale and Delivery for LINAK. For a copy hereof, please contact LINAK.