

System T3 - Highly flexible, low-vibration band chain

The E3-System combines low-noise operation, low sound level, simple installation and economy. The side plates that can be plugged into each other replace the conventional pin and bore connection and prevent relative movements between the joints, giving an almost complete freedom from wear. By the novel geometrical shape of the T band, hardly any polygon effect is generated operation. The T band operates in a very smooth arc giving extremely low vibration and noise. In order to reduce the manufacturing and installation costs, the T band is mounted in a length of 8 chain links. Due to its low mass, the igus® T band, combined with high speeds and accelerations, is suitable for applications with low fill weights and short strokes.

Typical industries and applications

- Printer and plotter
- Cleanroom applications
- Production and processing of semiconductors
- Optics
- Automatic insertion machines
- Measuring technology



igus® tests at 1 m measuring distance: = 33 dB(A)
for T3.29.050.038.0 at $v = 1 \text{ m/s}$ und 26.5 dB(A)
basic sound level



Cleanroom test
upon request



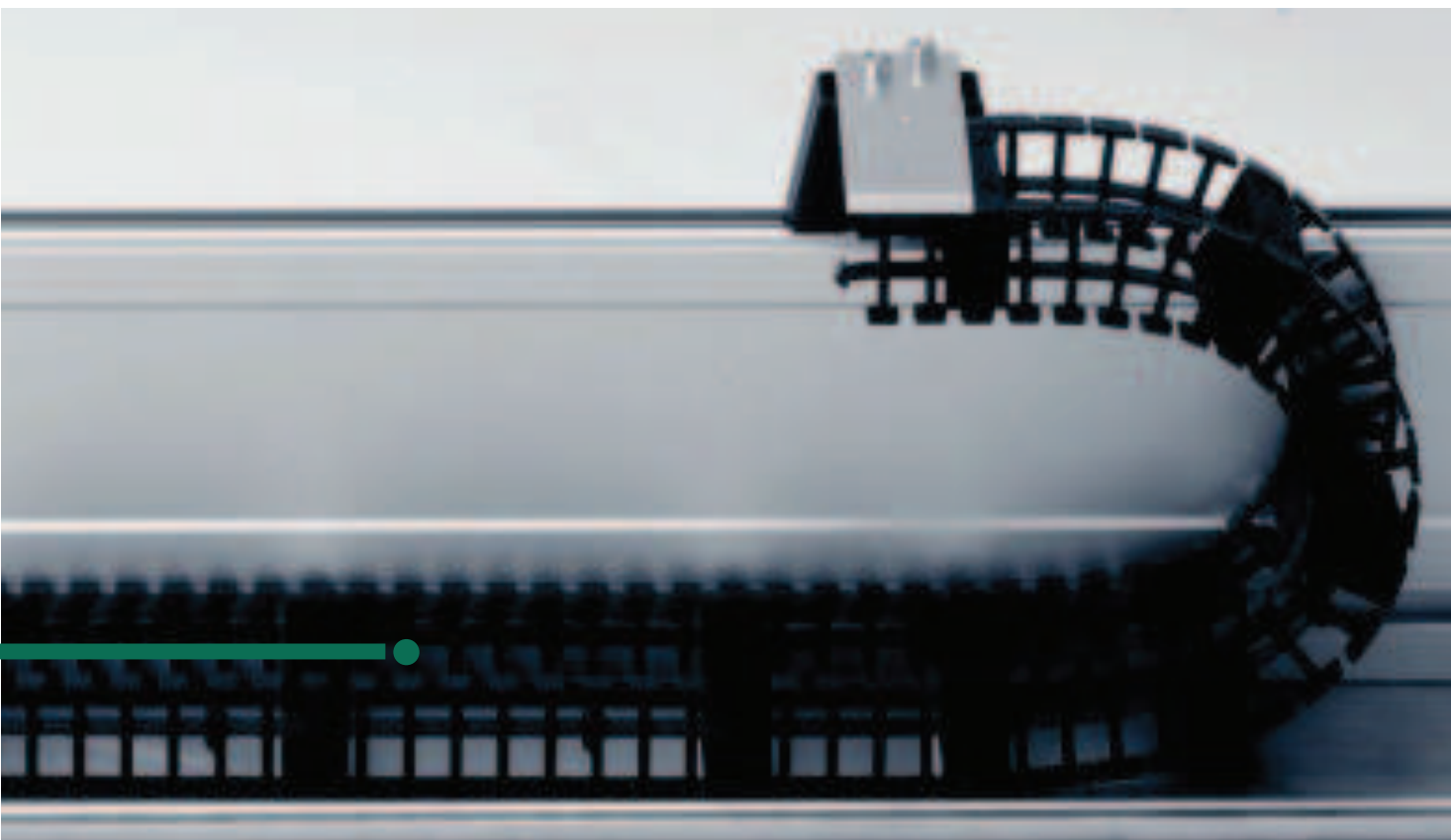

Extremely low noise - System T3 tests in the igus® lab at 1 m measuring distance showed a value of ≈ 33 dB(A) at 26.5 dB(A) basic sound level for Series T3.29.050.038



Testing facility at the igus® laboratory System T3 - ideal for high accelerations and short strokes



igus® System T3 T band chain - Inner height 29 mm

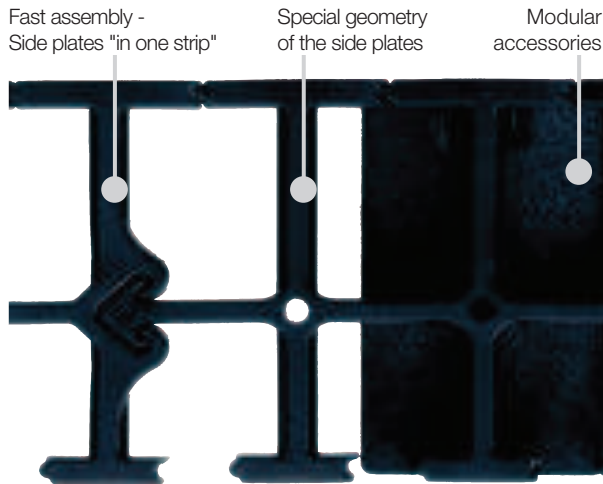

T3: E-Chain® band or highly dynamic applications

In the development of the 3-piece, T-shaped band chain "T3", the main focus was on minimum operational noise with lowest cost. This is achieved by the side-plate band consisting of 8 chain links in one piece, as well as the use of existing components of the popular E6 range. The T3 band chain is extremely flexible and runs "round" due to the special geometry. The omission of a pin and bore connection means the T3 band chain features extremely low abrasion and wear and hence is good for cleanroom applications.

- Extremely low noise and low vibration
- Low-priced E-Chain® for simple applications
- For high speeds and accelerations
- Very low weight
- Hardly any abrasion
- For short strokes
- Accessories: Separators, integrated strain relief, mounting brackets
- You can find more technical data about the material, chemical resistance, temperatures ► **chapter Design, from page 1.38**

Selection table

Series	Inner height <i>hi</i> [mm]	Inner width <i>Bi</i> [mm]	Outer width <i>Ba</i> [mm]	Outer height <i>ha</i> [mm]	Bending radius <i>R</i> [mm]	Unsupported length max. [m]	Page
T3.29.	29	30 - 120	55 - 145	35	038	≈ 1,45	8.28

System T3 | 3-piece E-Chain®

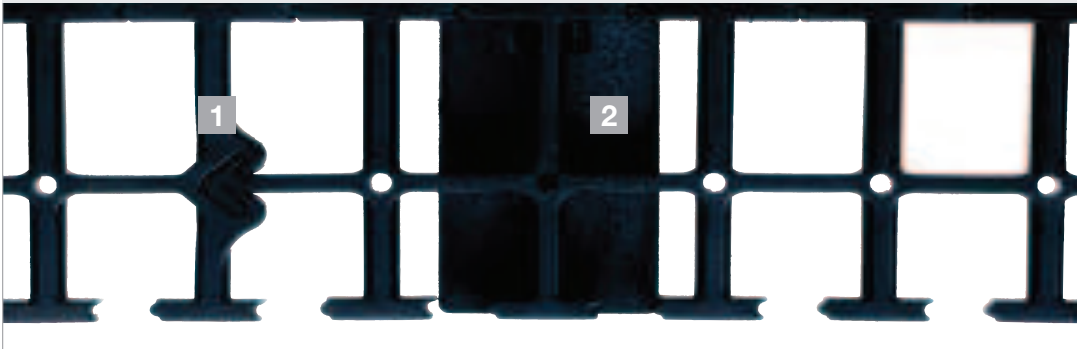

The abbreviation "T3" stands for a T-shaped E band, which consists of three basic elements:

- ① 2 side-plate bands (left/right)
- ② Separator element incl. separators

System T3 | Assembling



Side plates to be plugged into each other



Clip-on "interior separation clips"



System T3 enables quick installation times. The side plates can be simply plugged in

System T3 | Interior Separation | Strain Relief



Separators for dividing the chain cross section from the proven and tested E6 range (E6.29)

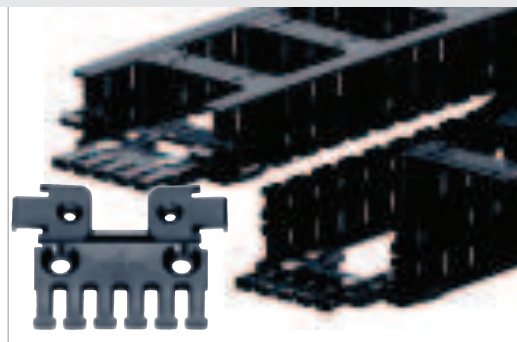

Universal strain relief through optional fixing bracket. You can fix the E-Chain® at the fixed end, if need be



● ● ● Price index



Extremely low noise
Test results upon request



Cleanroom test
upon request

- ❶ Side plates in one piece
- ❷ For high speed and high accelerations
- ❸ Angle bracket for housing a strain relief tiwrap plate
- ❹ 3-piece Design
- ❺ Easy shortening
- ❻ Accessories, such as interior separations and strain relief, are available
- ❼ Low weight
- ❽ Hardly any polygon effect



Fast assembly due to the side link strip



When to use the Series T3:

- At very high speeds and/or accelerations
- If a very light E-Chain® is required
- If a particularly low-cost E-Chain® is required
- For small bending radii and small spaces
- If easy filling and assembly is required
- Minimal abrasion (e.g. cleanroom applications)



When not to use it:

- When an E-Chain® is required for more fill weight
- ▶ Series E6.29, page 8.40
- When an enclosed E-Chain® is required for low noise operation
- ▶ Series R6.29, page 8.40



Order example complete E-Chain®

Please indicate chain-lengths or number of links Example: 1 m or 67 links

1 m T3.29.050.038.0



E-Chain®

with 2 separators E6.29.11 assembled every 2nd link



Interior separation

1 set T3.29.050.12



Mounting bracket



Unsupported length

FL_G = with straight upper run

FL_B = with permitted sag

Further information ► **Design, page 1.12**

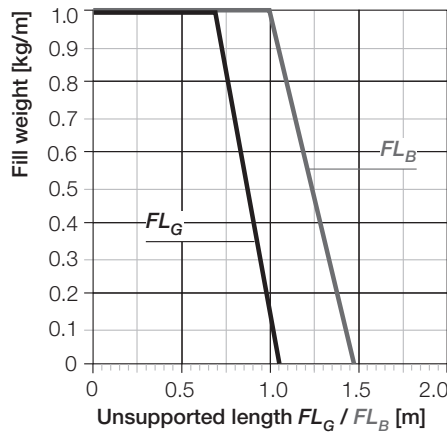
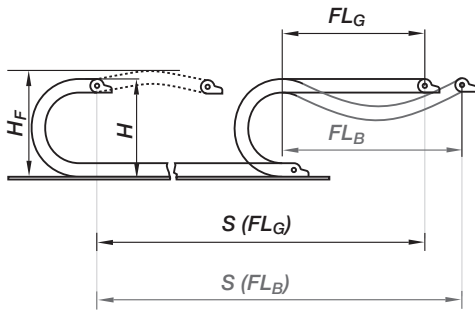

Length of travel S [m]

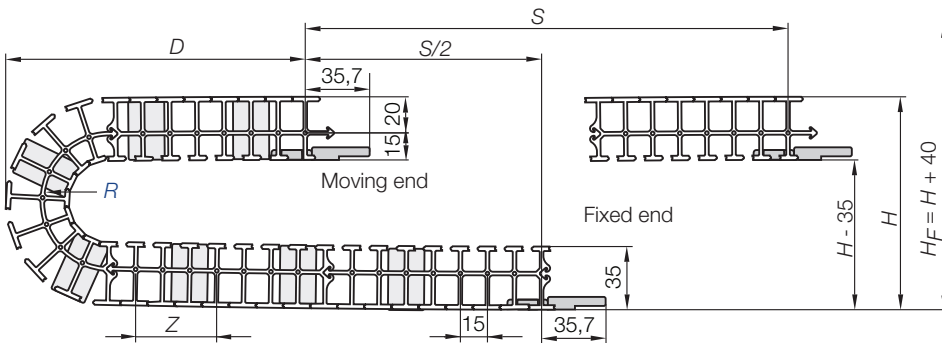
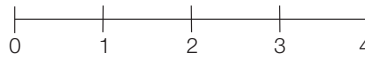

Pitch = 15 mm/link Links/m = 67 (1.005 mm) Chain length = $S/2 + K$

R (min.)	038
H (min.)	116
D	103
K	150

- S = Length of travel
- R = Bending radius
- H = Nominal clearance height
- H_F = Required clearance height
- D = Overlength E-Chain® radius in final position
- $K = \pi \cdot R + \text{"safety"}$
- Z = Distance of crossbars
(Standard: every 4th chain link)

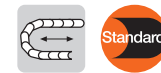

Short travels - unsupported

Unsupported E-Chains® feature positive camber over short travels. This must be accounted for when specifying the clearance height H_F . Please consult igus® if space is particularly restricted.

The required clearance height:
 $H_F = H + 40$ mm
 (with 1,0 kg/m fill weight)

Speed / acceleration FL_G	max. 20 [m/s] / max. 200 [m/s²]
Speed / acceleration FL_B	max. 3 [m/s] / max. 6 [m/s²]
Gliding speed / acceleration (maximum)	upon request
Material - permitted temperature °C	-40° up to +70° C
Flammability class	VDE 0304 IIC UL94 HB

Technical Data



Details of material properties

► page 1.38



System T3
Inner height: 29 mm

Phone +49- (0) 22 03-96 49-800
 Fax +49- (0) 22 03-96 49-222



► page 8.27

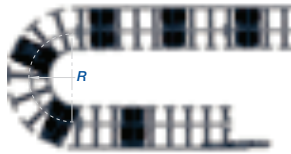
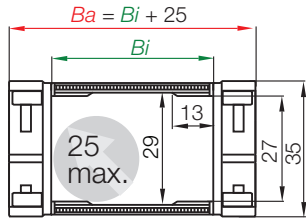

Part No. structure

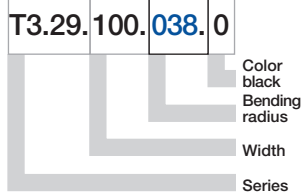

Series T3.29 - with crossbars every 2nd link

Part No.	B_i [mm]	B_a [mm]	R [mm]	Bending radii	Weight [kg/m]
T3.29.030.□.0	30	55	038		≈ 0,40
T3.29.040.□.0	40	65	038		≈ 0,42
T3.29.050.□.0	50	75	038		≈ 0,44
T3.29.060.□.0	60	85	038		≈ 0,46
T3.29.070.□.0	70	95	038		≈ 0,48
T3.29.080.□.0	80	105	038		≈ 0,50
T3.29.090.□.0	90	115	038		≈ 0,51
T3.29.100.□.0	100	125	038		≈ 0,53
T3.29.110.□.0	110	135	038		≈ 0,55
T3.29.120.□.0	120	145	038		≈ 0,57

Supplement Part No. with required radius. Example: T3.29.100.038.0

0 = standard color, other colors ► page 1.39 · Pitch = 15 mm/link - Links/m = 67



Interior separation elements

Distance "Z" for the interior separation elements of the T3 E-Chain®

Note: The first and last chain links should not be stuck with the interior separation elements!

As a standard, crossbars are mounted on every 4th chain link!

Part No. T3.29. 100. 038. 0

For other distances, e.g. every 6th chain link, change the part number as follows:

Part No. T3.29. 100. 038. Z6. 0

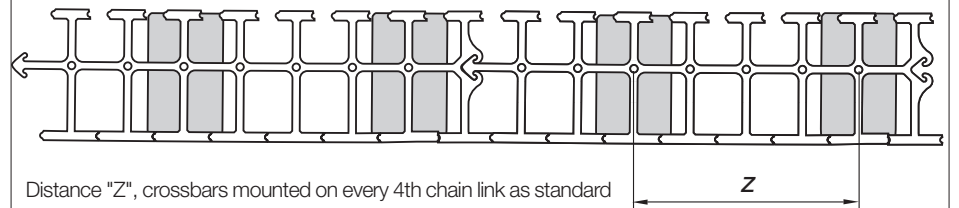

Option 1: Vertical separators

Vertical separators are used if a vertical subdivision of the E-Chain® interior is required -

By standard vertical separators are assembled every 4th E-Chain® link!

- **Standard** subdivision with vertical separator E6.29.11* (slotted 5 times), for combinations with full-width shelf 111.X
- **Notch separator** E6.29.11.R (slotted 5 times) can be locked in 2 mm increments due to gaps on the crossbars. For side-mounted applications and combinations with full-width shelf 111.X
- **Middle plate*** E6.29.12 for combinations with side plate E6.29.13, full-width shelf 221.X and shelf 2210.X
- **Strain relief separator** E6.29.12.Z (slotted 5 times), can be integrated into the mounting bracket and can be placed there at any point

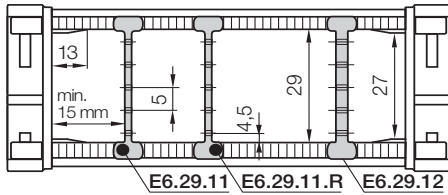

Vert. separator, slotted*

unassembled E6.29.01

assembled E6.29.11



Notch separator

unassembled E6.29.01.R

assembled E6.29.11.R

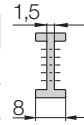

Middle plate*

unassembled E6.29.02

assembled E6.29.12

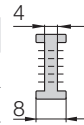

Strain relief separator

unassembled E6.29.02.Z

assembled E6.29.12.Z

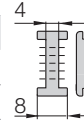

*no minimum space required!

System T3
Inner height: 29 mm

Option 2: Full-width shelves

For applications involving many thin cables with similar or identical diameters

- **Full-width shelf 111.X** for combinations with vertical separator E6.29.11 and notch separator E6.29.11.R
- **Full-width shelf 221.X** for combinations with middle plate E6.29.12, strain relief separator E6.29.12.Z, and side plate E6.29.13

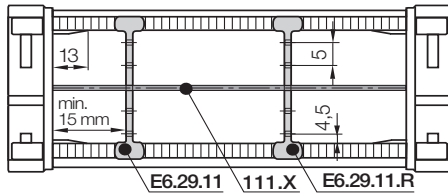

Width X [mm]	Part No. unassembled		Part No. assembled	
	110.X	220.X	111.X	221.X
030	110.30	220.30	111.30	221.30
040	110.40	220.40	111.40	221.40
050	110.50	220.50	111.50	221.50
060	110.60	220.60	111.60	221.60
070	110.70	220.70	111.70	221.70

Width X [mm]	Part No. unassembled		Part No. assembled	
	110.X	220.X	111.X	221.X
080	110.80	220.80	111.80	221.80
090	110.90	220.90	111.90	221.90
100	110.100	220.100	111.100	221.100
110	110.110	220.110	111.110	221.110
120	110.120	220.120	111.120	221.120

Full-width shelf

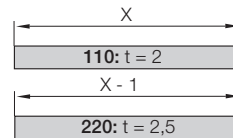

Option 3: Shelves

Shelves can be arranged elevator-shifted with different bottoms within the entire E-Chain® width

- **Shelf 2210.X** for combinations with middle plate E6.29.12, strain relief separator E6.29.12.Z and side plate E6.29.13

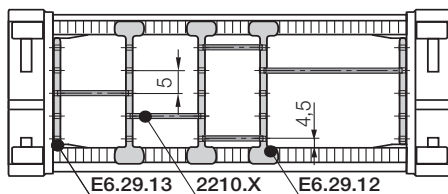

Width X [mm]	Part No. unassembled	Part No. assembled
	018	2200.18
023	2200.23	2210.23
028	2200.28	2210.28
033	2200.33	2210.33
038	2200.38	2210.38
043	2200.43	2210.43

Width X [mm]	Part No. unassembled	Part No. assembled
	048	2200.48
058	2200.58	2210.58
068	2200.68	2210.68
073	2200.73	2210.73
088	2200.88	2210.88
099	2200.99	2210.99

Side plate

unassembled E6.29.03

assembled E6.29.13

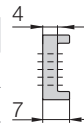

Shelf

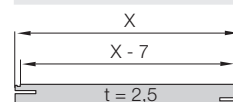

Phone +49- (0) 22 03-96 49-800
Fax +49- (0) 22 03-96 49-222

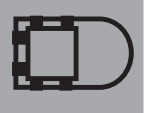

► page 8.27

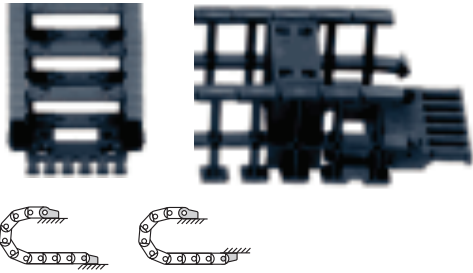

Plastic fastener

- Housing potential for strain relief tiwrap plate
- Firmly attached to the E-Chain®
- Minimized outer width
- Fastening of the E-Chain® possible on subsurface

Moving end
T3.29...2

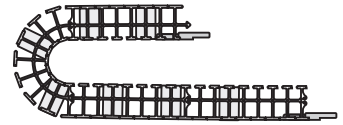

Example: Possible installation conditions for E3 mounting brackets

T3.29...1
Fixed end

Dimensions and order configurations

T3.29...2
Moving end

T3.29...1
Fixed end



Mounting angle, single

Part No. structure

T3.29.	030.	12
--------	------	----



Full set, for both ends:

T3.29.	030.	12
--------	------	----

Single-part order:

T3.29.	030.	1
--------	------	---

Moving end mounting bracket

T3.29.	030.	2
--------	------	---

Moving end mounting bracket

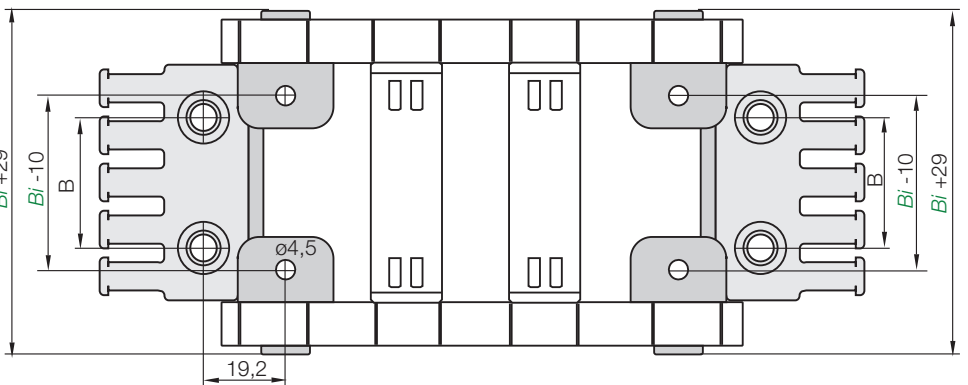

For E-Chain®	Part No. full set
T3.29.030	T3.29.030.12
T3.29.040	T3.29.040.12
T3.29.050	T3.29.050.12
T3.29.060	T3.29.060.12
T3.29.070	T3.29.070.12

For E-Chain®	Part No. full set
T3.29.080	T3.29.080.12
T3.29.090	T3.29.090.12
T3.29.100	T3.29.100.12
T3.29.110	T3.29.110.12
T3.29.120	T3.29.120.12

Phone +49- (0) 22 03-96 49-800
Fax +49- (0) 22 03-96 49-222

igus® GmbH
51147 Cologne

Internet: www.igus.eu
E-mail: info@igus.de

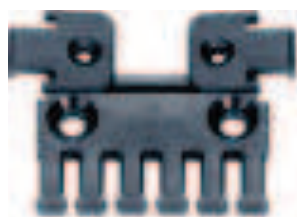

Mounting angle mit strain relief

T3 | Series T3.29 | Accessories | Strain Relief

igus® Chainfix tiwrap plate as individual part

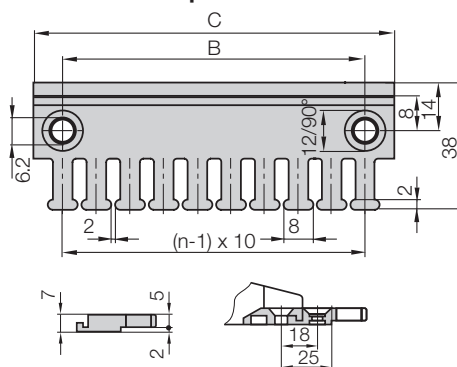

Tiwrap plate	n Number of teeth	Dim. C [mm]	Dim. B [mm]
2020.ZB	3	30	15
2030.ZB	4	40	20
2040.ZB	5	50	30
2050.ZB	6	60	40
2070.ZB	8	80	60
2090.ZB = (2030.ZB + 2040.ZB)	9	90	-
2100.ZB	10	100	80
2125.ZB = (2050.ZB + 2050.ZB)	12	120	-

Strain relief separator

Separator with integrated strain relief for the use in the first or last chain link. Individual part for the manufacturing of switchgear cabinets or for the assembly of machines. Easy to assemble without any screws ► **chapter 10.**

Part No.	Number of teeth	For Series
E6.29.02.Z	2 one side	T3.29 E-Chain®

