

Dimensions

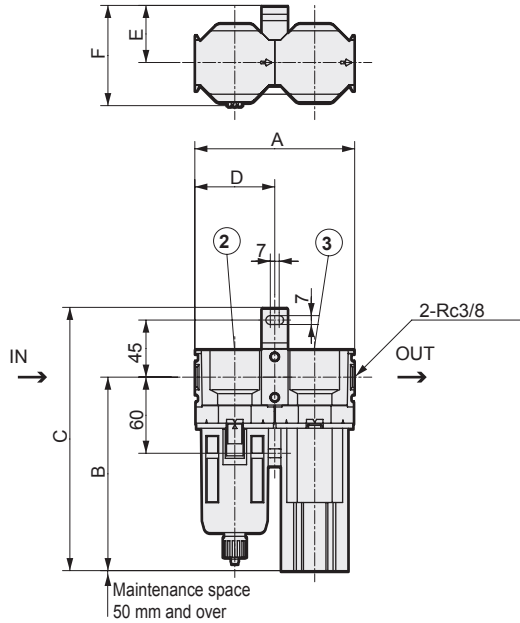

● Unit C1 type



	A	B	C	D	E	F	Weight (kg)
SU301E-*-W-C1	126	153	208	63	45	79	1.0
SU302E-*-W-C1	143	223	278	80	55	97	1.6
SU401E-*-W-C1	160	223	278	80	55	97	2.1
SU402E-*-W-C1	160	328	383	80	55	95	3.5

● Unit C2 type

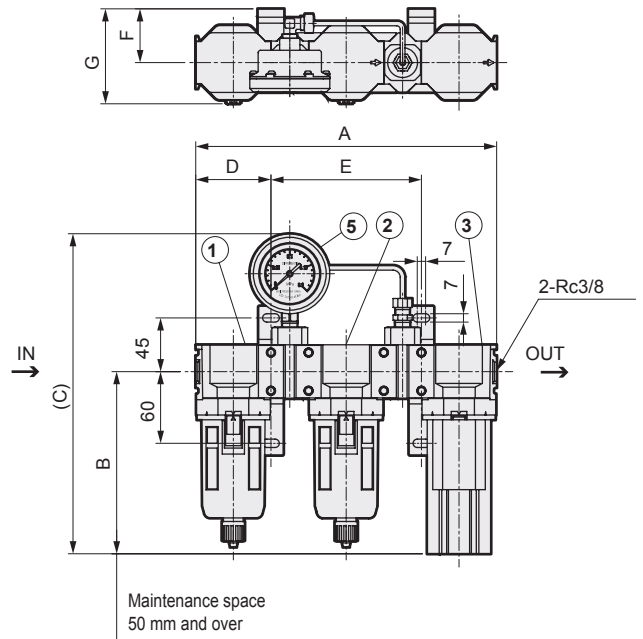

	A	B	C	D	E	F	G	Weight (kg)
SU301E-*-W-C2	252	153	268	63	126	45	79	2.0
SU302E-*-W-C2	286	223	338	80	143	55	97	2.8
SU401E-*-W-C2	303	223	338	80	143	55	97	3.3
SU402E-*-W-C2	303	328	443	80	143	55	97	4.7

● Unit C3 type

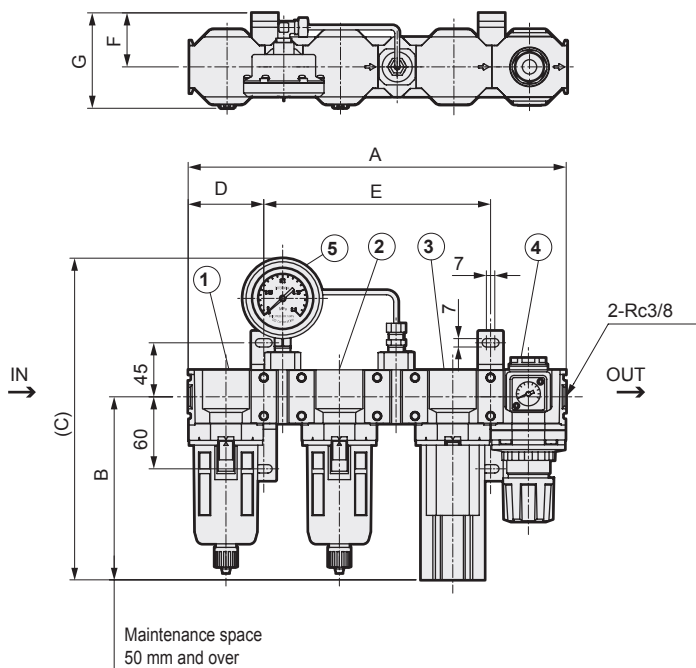

	A	B	C	D	E	F	G	Weight (kg)
SU301E-*-W-C3	315	153	268	63	189	45	79	2.5
SU302E-*-W-C3	366	223	338	80	206	55	97	3.5
SU401E-*-W-C3	383	223	338	80	223	55	97	4.0
SU402E-*-W-C3	383	328	443	80	223	55	97	5.4

● SD300E-SD400E

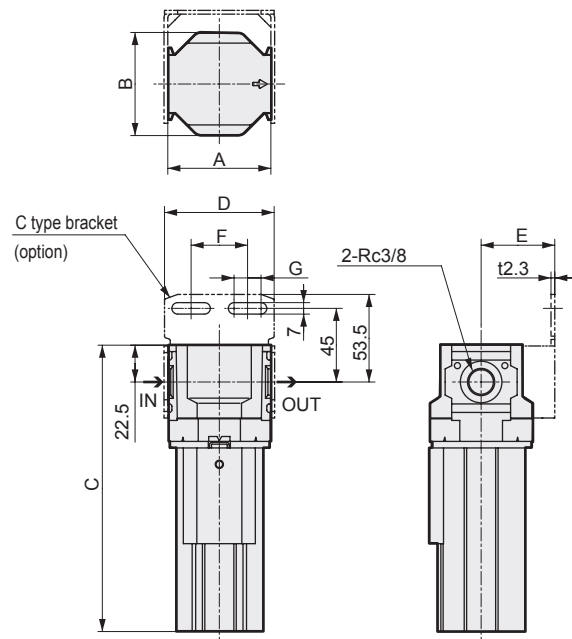

	A	B	C	D	E	F	G	Weight (kg)
SD301E-*-W	63	63	175	67	45	34.5	16.5	0.6
SD302E-*-W	63	63	245	67	45	34.5	16.5	0.9
SD401E-*-W	80	80	245	84	55	55	14	1.4
SD402E-*-W	80	80	315	84	55	55	14	1.8

F.R.L. unit

Pneumatic auxiliary components

Air unit components

Precision components

Pressure sensor

Sensor/controller

Total air system

Main line unit

Ending

Clean air unit

Air unit

High polymer membrane air dryer